

REINFORCE INTERSECTING WALLS -
"T" INTERSECTIONS

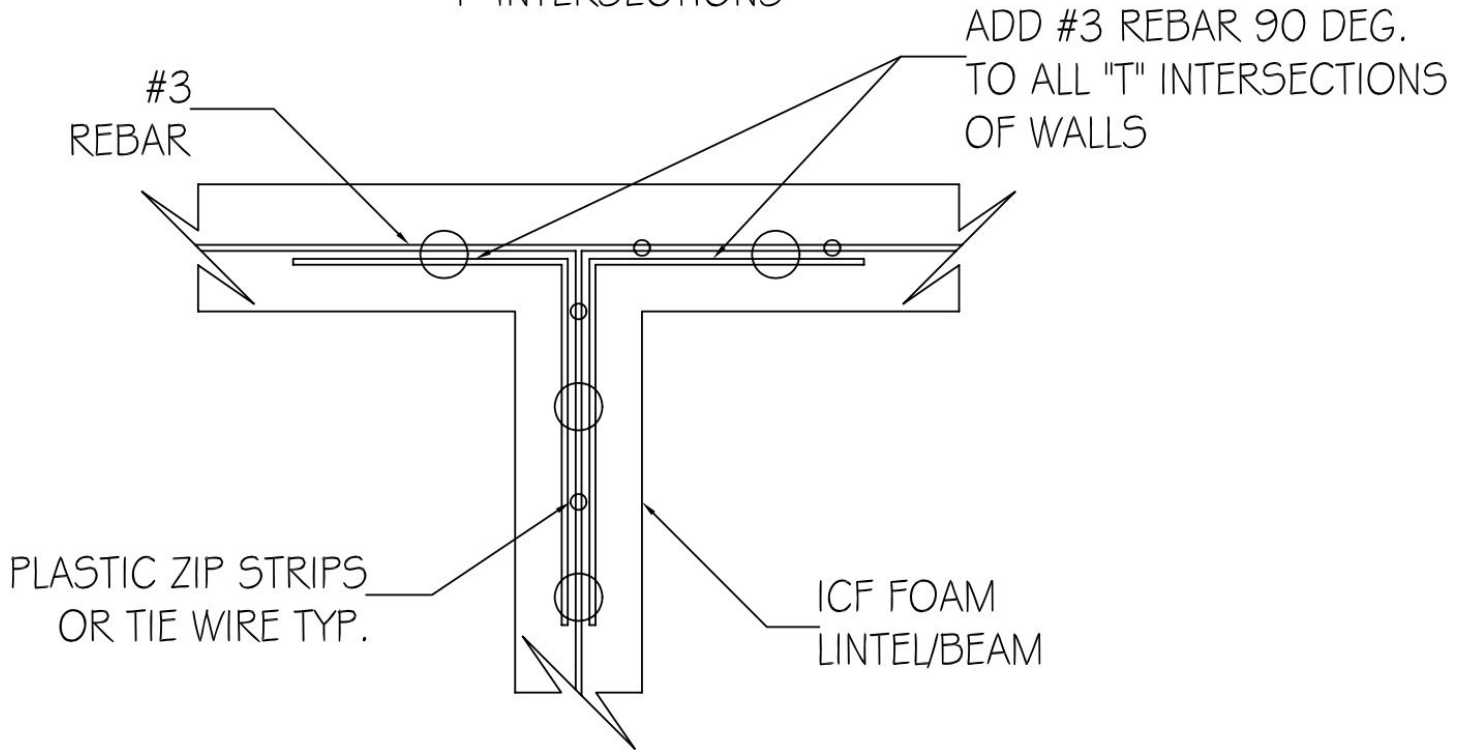

"T" INTERSECTIONS TO TIE IN WALLS AT 4' AND 8' HIGH BEAM/LINTELS



FastBlocs.com

T INTERSECTION REINFORCEMENT

DATE/REV	18/03/07
----------	----------

CONSTRUCTION SHALL BE IN ACCORDANCE WITH ALL APPLICABLE LOCAL AND NATIONAL CODES. ALL DRAWINGS ARE FOR EXAMPLE PURPOSES AND ARE TO BE USED AS A REFERENCE GUIDE ONLY.